



INSPECTION AND CONTROL

# R-Series Vision System

Smart. Flexible. Powerful.



Vision system

# Automatic Code Verification

## >> Reliable Coding Verification

The R-Series is Domino's range of smart vision systems, designed and optimised to work with our entire range of printers. It is now easier than ever to inspect every code and detect issues before they impact production.

The R-Series eliminates labour-intensive manual inspections, reduces waste and helps prevent the costs and brand damage associated with product recalls.

High-quality printers are only part of the solution. To maximise production uptime, minimise downtime and reduce waste, you also need effective print inspection. With more than 40 years of experience, Domino has developed a vision system that integrates seamlessly with Domino printers. The R-Series vision system is designed for integration into high-speed automated production lines, supporting up to 90,000 prints per hour.

### Flexible and future-proof

The R-Series can grow with your needs, with additional functionality added through simple software updates. This helps ensure that every product leaving your production line carries a correct and readable code.



### Protect your brand

- Verify the readability of every code;
- Avoid regulatory and retailer penalties;
- Reduce the risk of scrap, rework and product recalls;
- Eliminate costly manual inspections.

### Smart technology. Easy to use.

- Customised coding and inspection solution;
- Fully compatible with Domino printers and systems;
- Easy to install and operate;
- Scalable to support changing production requirements without replacing hardware.

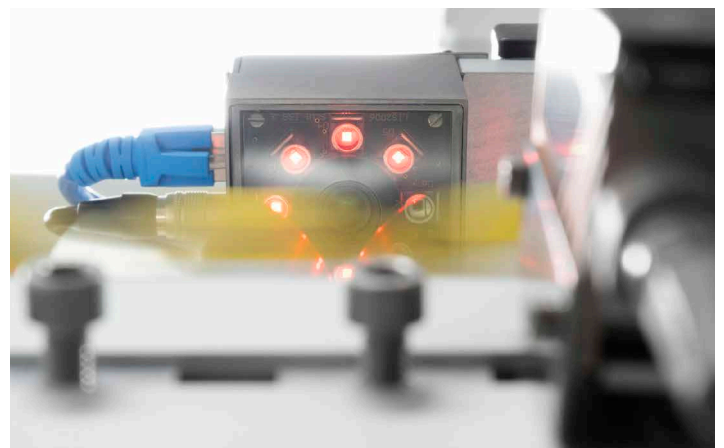

## R150 – Code Presence

Domino R150 verifies code presence and position for basic production protection.

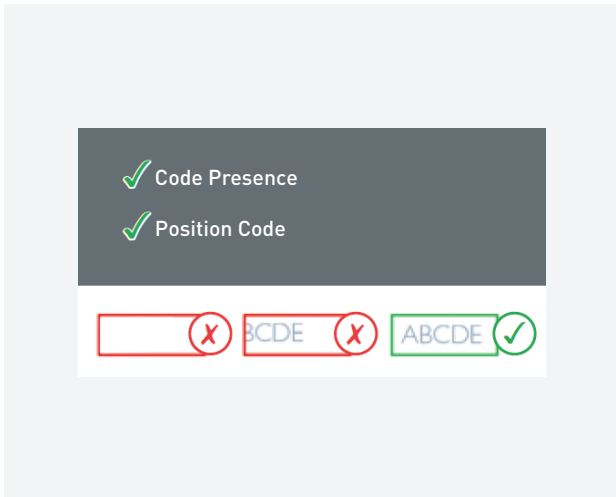

## R350 – Code Quality

The R350 detects common print quality issues and helps ensure the readability of printed codes.

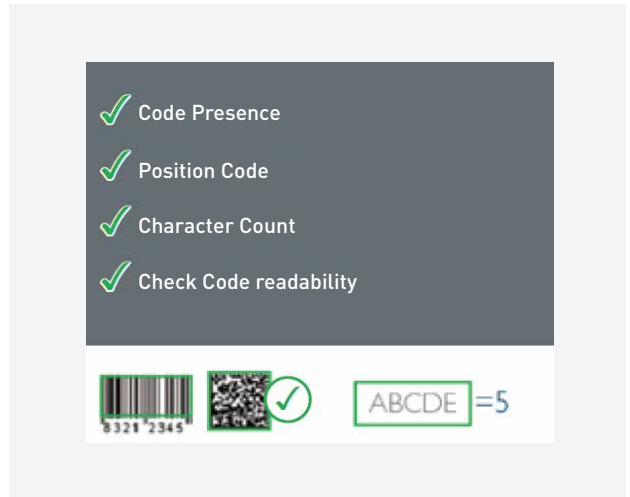

## R550 – Code Verification

Comprehensive code verification for reliable production and product integrity.

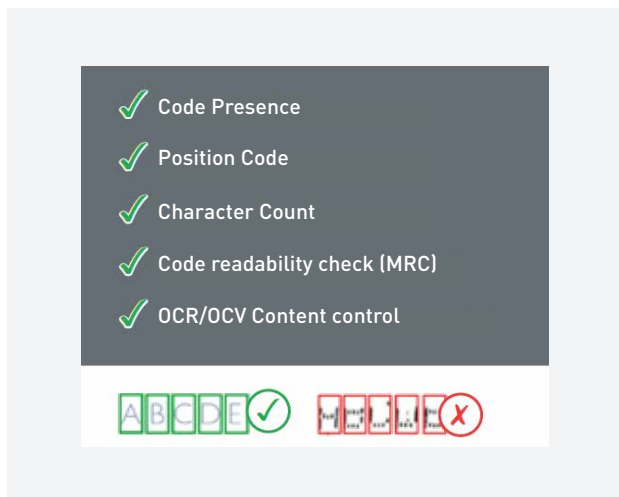

### TWO HARDWARE OPTIONS TO SUPPORT DIFFERENT PRODUCTION REQUIREMENTS

The **OEM R-Series** is designed for integration into control cabinets and applications requiring a single-camera system.

The **i-Tech R-Series** offers the processing power and functionality required for high-speed applications and production lines with advanced inspection and compliance requirements.



### Fast installation and minimal setup

Domino offers a wide range of preconfigured cameras and lighting systems, supplied with mounting brackets for fast and simple installation and seamless integration with Domino printers.

The software interface, combined with centralised label management software, enables automatic job handling and label selection through existing ERP and MES systems.



# Shared Technical Specifications for the R-Series

Performance	OEM R-Series	i-Tech R-Series
<b>Products/hour (max)</b>	60,000	90,000
<b>Camera system</b>	Single-camera system	Single and dual camera system
<b>Inspection areas (A0I)</b>	3 (R150) / 4 (R350, R550)	8 (R150) / 10 (R350, R550)
<b>Software Packages</b>		
<b>Advanced MRC package</b>	optional	included
<b>Barcode Grading</b>	n/a	optional
<b>Second camera license</b>	n/a	optional
<b>Hardware Options</b>		
<b>Controller without touchscreen</b>	n/a	optional
<b>Controller with touchscreen</b>	n/a	standard
<b>Line-scan camera</b>	n/a	optional
<b>Controller Specifications</b>		
<b>Dimensions (L x W x H)</b>	Standard OEM version: 175 mm x 84 mm x 57 mm	Standard variant with touchscreen: 300 mm x 400 mm x 150 mm
<b>Weight</b>	0.78 kg	12 kg
<b>Protection rating</b>	IP4xx	IP65
<b>Inputs</b>	2 generics	2 generics
<b>Outputs</b>	4 programmable outputs	
<b>Ports</b>	Ethernet, GigE Ethernet, VGA, USB x 2, mini DP	5-port network switch, 3x GigE Ethernet, 4x USB
<b>Power</b>	110–240 V AC, 50–60 Hz 3-pin plug Output: 24 V DC	110 to 240 V AC, 50 to 60 Hz 180 mA maximum at 230 V AC

OEM Controller

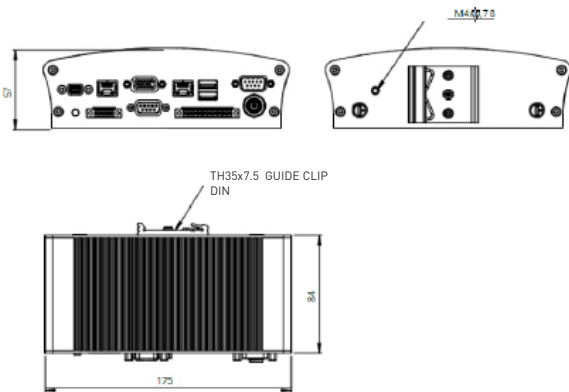

i-Tech Controller

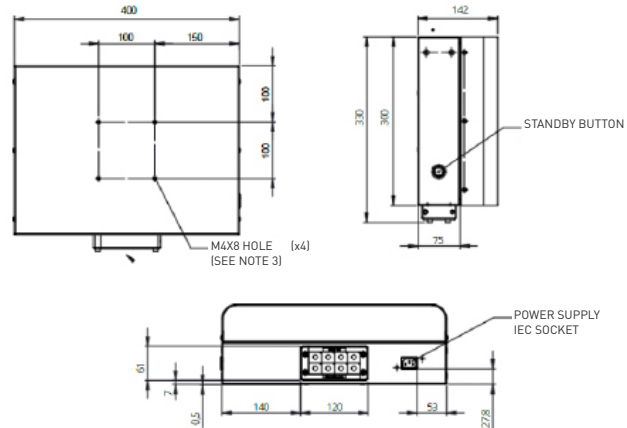

## DISCOVER NIMAX DIGITAL INNOVATIONS



Line Strategy is the application that gives you full control of your production line from a single workstation:

- Connects machines of any brand on the line;
- Reduces human error and enables centralized production control;
- Provides real-time reports on production performance;
- Reduces costs and streamlines tooling, control, and maintenance processes;
- Interfaces with company MES and ERP systems.



MyNimax Service Portal is your central platform for managing your Nimax machine fleet:

- AI-powered support with ai.max, available 24/7 for fast issue resolution;
- Integrated e-shop for easy ordering of consumables and spare parts;
- Unlimited remote assistance from our technical support team;
- Complete service and maintenance history.

DISCOVER MORE

